

DE ROSA

CATALO**GO!**





“ Qui c'è l'esperienza di chi ha toccato la passione,
la storia di chi ha saputo interpretare la velocità e la bellezza.
Il cuore di chi lavora con le mani, con l'immaginazione,
con la creatività per far nascere un nuovo telaio.
E l'anima, che distingue ogni nostra bicicletta e
rende unica la storia di chi ci accompagna.
È questo che ci rende orgogliosi e felici, ancora oggi. ”

Danilo e Cristiano De Rosa



Il Carattere da domare.

Se ambisci alla performance, il carbonio è fatto su misura per te.

Character to tame.

If you ache for performance, carbon fiber is made specifically for you.

Quando nasce una nuova bicicletta alla De Rosa, c'è sempre una domanda visionaria che ci facciamo: cosa sogna veramente un ciclista che ama pedalare? La sua aspirazione viene prima di tutto, perché è lì che sta la passione e il legame fra una bici e chi vi monta in sella. La tecnologia, la precisione, il dettaglio minuto seguono. E danno corpo a quel sogno.

Il carbonio è stata la risposta che abbiamo dato al sogno di chi vuole competere e avere una sfida davanti. Con se stessi, prima che in gara. Chi pedala senza indugi cerca la leggerezza, la performance massima, la stabilità. Cerca una bicicletta, fatta ad hoc, che segua i suoi movimenti, gli sforzi, i muscoli del corpo e li esalti all'ennesima potenza. È una cosa che il ciclista capisce subito, innamorandosi del design di quella bicicletta che lo farà resistere e vincere. La Protos è nata da questo sogno.

#racing #designtecnologia #aerodinamica #innovazione

Prior to conceptualizing the birth of a new bike at De Rosa, we collectively ask ourselves the following question: what creates the love affair between a cyclist and his or her bike? First and foremost is their aspiration because from this stems the passion that creates the unbreakable connection between cyclist and bicycle. Technology, precision, and attention to minute detail flow from there and provide substance to the dream!

Carbon fiber was the answer to that first question at the very beginning of the dream, and it became the solution for the cyclists who want to ride and race and challenge themselves at every level of cycling. Cyclists who need instant response look for lightness, maximum performance, and stability. Their bicycle must support their specific purpose, supporting and replicating their every movement and muscular effort without skipping a beat, providing confidence to the nth degree. A bicycle that responds this way is something that every cyclist dreams of, understands, and gravitates to immediately, falling in love with the design of the bicycle that will support every one of his or her aspirations. The Protos was born of this dream.

#racing #designandtechnology #aerodynamics #innovation





“Faccio il granfondista da anni, e mi alleno ogni giorno, si sa. So cosa significa velocità e sicurezza, e volevo una bici che lo sapesse quanto me. Quando mi avete consigliato la Protos, dicendomi che è stata pensata per soddisfare il sogno di ogni ciclista, ho preferito prenderla in mano e provarla subito. Ci conosciamo, sapete che sono di poche parole. Me l'avete data, ridendo un po' perché avevate già capito che non ve l'avrei più portata indietro. Infatti è rimasta con me. Perché? Beh, in poche parole: è una bici che assorbe le vibrazioni e cede energia. C'è un dialogo intenso in perfetto silenzio, quello tra me e lei. Grazie. » **Giulio**

“Come faccio a pedalare ogni giorno, a sudare, a lavorare anche 10 ore e poi montare in sella? Molti amici me lo chiedono, io sorrido e dico loro: guardate questa bici, guardate che linee, toccate queste giunture e sollevatela per sentire questo materiale. Allora capiscono cos'è il design, cos'è la perfezione e perché lì trova spazio una passione così grande. Anzi due: la mia che pedalo, quella di De Rosa che me lo fa fare. » **Marco**



“I've been a Gran Fondo participant for years; I ride and train every day. I know exactly what speed and responsiveness mean and I wanted a bike that understands it as well as I do. When you advised me to ride a Protos, telling me that it was designed to satisfy every cyclist's dream, I chose to test the bike immediately and put it through its paces. We know each other well and therefore now that I am a man of few words. When you gave me the bike to test you smiled, knowing me well enough to realize that you were not going to get the bike back! Of course, you were right, the bike remained with me. Why? Well, in a nutshell, the Protos is a bike that absorbs vibrations and transmits energy. The Protos and I have a very intense and continuous dialogue - in perfect silence; we understand each other perfectly. Thank you. » **Giulio**

“How am I able to ride every day, to sweat, to work even 10 hours a day and then go out for a ride? A lot of friends ask me, I smile and say: “just take a look at this bike, look at the lines, touch the joints and lift it to feel this material!” That is when they understand the true meaning of the word “design”, what is meant by the word “perfection”, and why I have such a great passion to ride. Actually, there are two passions involved; my passion for cycling and the passion of De Rosa that causes me to! » **Marco**



IL CARATTERE
PER COMPETERE



PROTOS



PROTOS

BIANCO

Group: super record disc 12v meccanico
Wheels: bora one disc
Handlebars: fsa integrated 5d
Saddle: slr selle italia

Tires: vittoria corsa
Bottlecage: elite carbon
Pedals: keo blade look

PROTOS



PROTOS

NERA

Group: durace di2 disco
Wheels: durace shimano
Handlebars: fsa integrated 5d
Saddle: slr selle italia

Tires: vittoria corsa
Bottlecage: elite carbon
Pedals: keo blade look



PROTOS

GREY

Group: super record 12v meccanico
Wheels: bora ultra
Handlebars: fsa integrated 5d
Saddle: slr selle italia

Tires: vittoria corsa
Bottlecage: elite carbon
Pedals: keo blade look



PROTOS

ROSSO

Group: ultegra di2 disc
Wheels: fulcrum r4
Handlebars: fsa k-force
Stem: fsa os 99

Saddle: slr selle italia
Tires: vittoria corsa
Bottlecage: elite carbon
Pedals: keo blade look



PROTOS

TEAM NIPPO

Group: super record eps 11v
Wheels: bora ultra
Handlebars: fsa kforce
Stem: fsa os 99

Saddle: slr team edition
Tires: irc
Bottlecage: elite carbon
Pedals: keo blade look



PROTOS TEAM ISRAEL

Group: durace di2 con guarnitura fsa power box
Wheels: fsa vision
Handlebars: fsa integrated 5d

Saddle: slr selle italia
Tires: schwalbe
Bottlecage: elite carbon



PROTOS TEAM CAJA

Group: durace di2
Wheels: miche super type
Handlebars: deda
Stem: deda

Saddle: selle italia slr
Tires: vittoria corsa
Bottlecage: sk

LO STILE DEL
RACING,
LA TECNOLOGIA
DELLA VELOCITÀ



SK PININFARINA

BIANCA

Group: super record 12v meccanico disco
Wheels: bora disco campy
Handlebars: ursus integrated stem
Saddle: selle italia slr

Tires: vittoria corsa
Bottlecage: elite carbon
Pedals: keo blade look



SK PININFARINA

ROSSO FUOCO db

Group: chorus h11 disco
Wheels: bora
Handlebars: ursus integrated stem
Saddle: selle italia slr

Tires: vittoria corsa
Bottlecage: elite carbon
Pedals: keo blade look



SK PININFARINA

BLU LORD

Group: durace elettronico
Wheels: durace shimano
Handlebars: ursus integrated stem
Saddle: selle italia slr

Tires: vittoria corsa
Bottlecage: elite carbon
Pedals: keo blade look



SK PININFARINA

CAVIALE

Group: ultegra elettronico
Wheels: fsa vision metron
Handlebars: ursus integrated stem
Saddle: selle italia slr

Tires: vittoria corsa
Bottlecage: elite carbon
Pedals: keo blade look



SK PININFARINA

GREY/SILVER

Group: super record 12v meccanico
Wheels: bora campy
Handlebars: ursus integrated stem
Saddle: selle italia slr

Tires: vittoria corsa
Bottlecage: elite carbon
Pedals: keo blade look



SK PININFARINA

NERO TERRA DISK

Group: durace elettronico disk
Wheels: durace disk shimano
Handlebars: ursus integrated stem
Saddle: selle italia slr

Tires: vittoria corsa
Bottlecage: elite carbon
Pedals: keo blade look



SK PININFARINA

F1

Group: record 12v meccanico
Wheels: bora
Handlebars: fsa k-force
Stem: fsa os 99

Saddle: selle italia slr
Tires: vittoria corsa
Bottlecage: elite carbon
Pedals: keo blade look



SK PININFARINA

ROSSO VULCANO db

Group: sram e-tap
Wheels: fsa vision
Handlebars: ursus integrated stem
Saddle: selle italia slr

Tires: vittoria corsa
Bottlecage: elite carbon
Pedals: keo blade look



SK PININFARINA

ISRAEL

Group: fsa k-force elettronico
Wheels: fsa vision
Handlebars: fsa k-force
Stem: fsa os 99

Saddle: selle italia slr
Tires: shwalbe
Bottlecage: elite carbon

IL CARBONIO
CHE CORRE
CONTRO IL TEMPO

KING



KING
BIANCO LUCIDO

Group: super record 12v meccanico
Wheels: bora campy
Handlebars: fsa k-force
Stem: fsa os 99

Saddle: selle italia slr
Tires: vittoria corsa
Bottlecage: elite carbon
Pedals: keo blade look



KING
GREY

Group: super record 12v meccanico
Wheels: bora ultra campy
Handlebars: kforce fsa
Stem: fsa os 99

Saddle: selle italia slr
Tires: vittoria corsa
Bottlecage: elite carbon
Pedals: keo blade look



KING
BOB BLACK

Group: durace meccanico
Wheels: fsa vision metron
Handlebars: fsa k-force
Stem: fsa os 99

Saddle: selle italia slr
Tires: vittoria corsa
Bottlecage: elite carbon
Pedals: keo blade look



KING
BLU NAVY

Group: durace di2
Wheels: durace shimano
Handlebars: ursus integrated stem
Saddle: selle italia slr

Tires: vittoria corsa
Bottlecage: elite carbon
Pedals: keo blade look



KING
SABBIA

Group: ultrega di2
Wheels: fsa vision metron
Handlebars: fsa k-force
Stem: fsa os 99

Saddle: selle italia slr
Tires: vittoria corsa
Bottlecage: elite carbon
Pedals: keo blade look



KING

VERDE MILITARE

Group: ultegra meccanico
Wheels: r0 fulcrum
Handlebars: fsa k-force
Stem: fsa os 99

Saddle: selle italia slr in manganese
Tires: vittoria corsa
Bottlecage: elite carbon
Pedals: keo max look



KING

RED

Group: sram e-tap
Wheels: fsa vision metron
Handlebars: ursus integrated stem
Saddle: selle italia slr

Tires: vittoria corsa
Bottlecage: elite carbon
Pedals: keo blade look

LO STILE
DA VENDERE

IDOL



IDOL

BOB

Group: potenza 11v meccanico disk
Wheels: zonda campy
Handlebars: fsa energy
Stem: fsa sl-k

Saddle: selle italia slr
Tires: vittoria rubino pro
Bottlecage: elite custom race
Pedals: keo max look



IDOL
FULL WHITE

Group: ultrega meccanico
Wheels: fulcrum r4
Handlebars: fsa energy
Stem: fsa sl-k

Saddle: selle italia x3
Tires: vittoria rubino pro
Bottlecage: elite custom race
Pedals: keo max look



IDOL
ROSSO

Group: chorus h11 disc meccanico
Wheels: shamal ultra campy
Handlebars: fsa sl-k
Stem: fsa sl-k

Saddle: selle italia slr in manganese
Tires: vittoria rubino pro
Bottlecage: elite custom race
Pedals: keo max look



IDOL
BLU POTENZA

Group: potenza 11v meccanico
Wheels: campy scirocco
Handlebars: fsa energy
Stem: fsa sl-k

Saddle: selle italia slr
Tires: vittoria rubino pro
Bottlecage: elite custom race
Pedals: keo max look



IDOL
F1

Group: ultegra meccanico disk
Wheels: fulcrum r4
Handlebars: fsa energy
Stem: fsa sl-k

Saddle: selle italia slr
Tires: vittoria rubino pro
Bottlecage: elite custom race
Pedals: keo max look

GIOVANI
SI DIVENTA

NICK



NICK
BLUETTE

Group: 105 meccanico
Wheels: f7 fulcrum
Handlebars: fsa vero compact
Stem: fsa os 168

Saddle: selle italia x3
Tires: zaffiro vittoria
Bottlecage: elite custom race
Pedals: keo classic look



NICK

NERA BOB

Group: ultragra meccanico
Wheels: 7 fulcrum
Handlebars: fsa vero compact
Stem: fsa os 168

Saddle: selle italia x3
Tires: zaffiro vittoria
Bottlecage: elite custom race
Pedals: keo classic look



NICK

FAEMA

Group: centaur meccanico
Wheels: khamsin campy
Handlebars: fsa vero compact
Stem: fsa os 168

Saddle: selle italia x3
Tires: vittoria zaffiro
Bottlecage: elite custom race
Pedals: keo classic look



Nobile, resistente. Fedele.

Dal titanio nasce l'anima De Rosa.

*Noble, resilient, trustworthy.
From Titanium is born the Soul.*

Con lui, ci conosciamo da 25 anni. Questo materiale fidato che è il titanio, lo abbiamo apprezzato fin da subito accogliendo la sfida che ci lanciava: capire a fondo la sua resistenza e imparare a trasformarla in stile. È stata la passione che nutriamo da anni a darci la chiave di lettura per modellarlo e per restituire a chi pedala le sue proprietà meccaniche e il comfort che trasmette. Siamo stati fedeli alla nostra conoscenza costruita nel tempo, perché ci piace essere autentici. E abbiamo usato la nostra fantasia, per costruire un progetto che avesse anima. È servito mescolare tecnologia, cuore e attenzione, perché poi è nel titanio che sta racchiuso il meglio della cultura telaistica italiana. Non abbiamo mai smesso di curarlo e sperimentarne le forme di bellezza possibili, finché è nata lei, la nuova arrivata alla De Rosa Factory: Anima.

#essereveri #essereautentici #biciclettadell'anima

Titanium. We have known and relied on each other, and have collaborated in providing customers with an impeccable cycling experience, for 25 years. From the very start we welcomed the challenge that launched our partnership: to be able to fully understand your essence in order to infuse it with incredible style. For years we have been nourishing a passion that would answer this question: what is the critical combination of substance and style that will transmit the ultimate riding experience to the cyclist who rides titanium. We are always faithful to the depth of knowledge we have developed over time because we like being authentic however, we always rely on our imagination to develop and build bicycles that have soul. We took advantage of the opportunity to combine technology and attention to detail and style in order to imbed the titanium with the all the best attributes of Italian frame building culture. We did not stop experimenting and creating until the very last moment prior to the birth of the latest addition to the De Rosa lineup: Anima. **#bereal #beauthentic #bicyclefromthesoul**





“Vi ho seguiti nell'ultimo anno da dietro le quinte, immaginando come sarebbe stata. Non rinunciate mai a nuove avventure, eh? Classica come è il titanio, nuova come ogni corsa. Fresca e sapiente. Meditativissima (ho visto quel carro posteriore un po' ribassato, che stile!). Non si può non avere, lo sapete, no? » **Paolo**

“Sei una sintesi! Quando ho cominciato a pedalare, c'era una De Rosa ad aiutarmi. C'eravate voi a darmi consigli e a farmi provare i modelli. Parlando e provando, ho trovato la mia misura e vi ho conosciuti - Nicola ci guardava discutere e poi se ne usciva con un consiglio unico.

Adesso che vedo Anima (grazie di avermela fatta provare), mi pare di vedere tutta la maestria di anni condensata in un futuro che tengo in mano. È un +1, senza un che di superfluo. Stili che rimangono, insomma. » **Luca**



*“I have followed you throughout the last year from behind the scenes, imagining how it would turn out. I realized that you never give up, you are always interested in new adventures. Your creation is as classic as the titanium it is made from and yet, is new and exciting like every bike race. Fresh and new yet wise; almost meditative. (I saw that rear carriage a little lowered, what style!). You realize that this is a “must have”, don't you! » **Paolo***

*“You are a synthesis! When I started cycling there was a De Rosa to help me. You were there to give me advice and let me try the models. Speaking and trying, I found my measure and I got to know you - Nicola watched and listened to our discussion then provided the perfect advice. Now that I see Anima (thank you for letting me try it), I seem to see all the mastery of past years condensed into a future that I hold in my hand. It's a +1, without something superfluous. In short, a style that lasts forever. » **Luca***

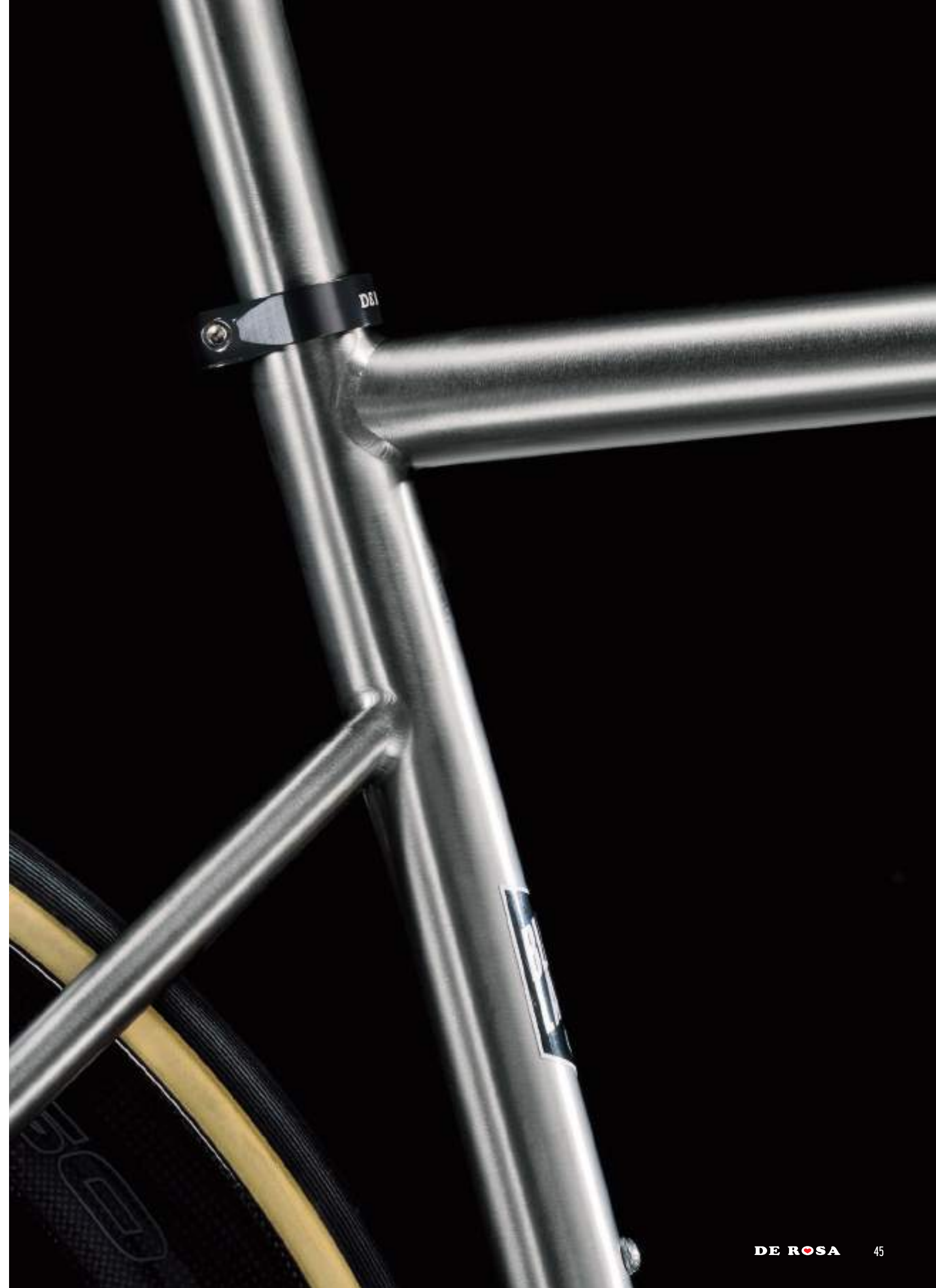

UN PEDALARE
AUTENTICO

ANIMA



ANIMA

Group: super record disc 12v meccanico
Wheels: bora one disc campy
Handlebars: fsa k-force
Stem: fsa os 99

Saddle: selle italia sp01
Tires: vittoria corsa tubolari
Bottlecage: elite carbon
Pedals: keo blade look

LA MECCANICA
DELLA PRECISIONE

Solo



SOLO

Group: super record 12v meccanico
Wheels: bora campy
Handlebars: fsa k-force
Stem: fsa os 99

Saddle: selle italia slr
Tires: vittoria corsa
Bottlecage: elite carbon
Pedals: keo blade look

L'ESSENZA
DEL TEMPO

TREDUECINQUE



TREDUECINQUE

ROSSO

Group: super record 12v meccanico
Wheels: fsa vision metron
Handlebars: fsa k-force
Stem: fsa os 99

Saddle: selle italia slr
Tires: vittoria corsa
Bottlecage: elite carbon
Pedals: keo blade look



La lega della tenacia.

Non ci si stanca mai delle cose perfette,
resistono come acciaio.

The legacy of tenacity.

We never tire of perfect things, they resist change just like steel.

1953. Oggi, 2018. Ogni tanto ci fermiamo a pensare al tempo che c'è in mezzo a queste date, che è poi il tempo dell'acciaio: pura resistenza. Sì, perché l'acciaio ha saputo dare inizio alla tradizione dei telai De Rosa senza mai finire - Ugo l'aveva capito benissimo, da innovatore com'è. È la tenacia di un materiale resistente come pochi, in grado di superare mode e tendenze e di unire le passioni dei padri a quelle dei figli e dei nipoti che verranno. Chi pedala con l'acciaio, pedala con resistenza alla fatica e alle deformazioni del tempo. Cerca la forza e trova anche il comfort.

Ecco perché le nostre biciclette in acciaio, come la Corum, ti danno soddisfazione ogni giorno lasciandoti anche un po' stupito che tanta solidità sia trasformata in un capolavoro di maneggevolezza. Del resto, il meglio nasce quando storia, visione di futuro e passione pedalano assieme.

#storiaefuturo #resistenza #invenzione

It began in 1953; today we are in 2018. From time to time we stop to think about the years between. During all these years, at the very beginning of what has become the De Rosa tradition, steel has provided a foundation that has never wavered, remaining true to its nature, resisting change. Sig. Ugo, being an innovator, understood this very well. Steel has the tenacity of a resistant material that very few others can claim; it is able to withstand the onslaught of fashions and trends and simultaneously unite the passions of fathers and mothers with those of the children and grandchildren not yet here. Cyclists who ride steel do so with resistance to fatigue and the passing of time; they search for strength and find comfort along the way.

That's why our steel bicycles, like the Corum, are able to provide one with pleasure every day while leaving you just that little bit amazed at how something so solid can be transformed into a masterpiece of maneuverability. The answer of course is this: the best possible outcome is born when history, a vision for the future and passion ride together!

#historyandfuture #resistanttochange #invention





“Io sono uno che guarda ai dettagli. Il bello sta lì. L'acciaio saldato a Tig è la perfezione per una bicicletta. Non a caso avete impiegato una tecnologia che è nata dall'industria aeronautica. Ecco come si fa innovazione sul serio! » **Pietro**

“Dico a mio figlio: monta in sella alla Corum, e capirai che la storia non è cosa da museo. È esperienza viva che ti dà sempre nuove soddisfazioni. Ovviamente perché dietro c'è cuore, c'è anima, c'è voglia di futuro. » **Mattia**

“Grazie dei sabati mattina passati a chiacchierare da voi provando, toccando e ascoltando le vostre biciclette. » **Sara**



“I am someone who pays attention to detail. I clearly see the beauty. Tig welded steel is perfect for a bicycle. It is no coincidence that you have used a technology that originated in the aeronautical industry. This is how serious innovation is performed! » **Pietro**

“I say to my son: “ride a Corum, and you will understand that history is not about being in a museum. History is created by participating in live experiences that give you feelings of satisfaction. Naturally, when the experience contains heart and soul, there is a desire for the future.” » **Mattia**

“Thank you for all the Saturdays we spent together discussing, feeling and testing your bicycles. » **Sara**



L'ACCIAIO
RACING

Corum



CORUM
NERO REVO

Group: super record 12v meccanico
Wheels: shamal ultra campy
Handlebars: fsa k-force
Stem: fsa os 99

Saddle: selle italia slr
Tires: vittoria corsa
Bottlecage: elite carbon
Pedals: keo max look

Corum



CORUM
ROSSO REVO

Group: chorus 11v meccanico
Wheels: shamal ultra campy
Handlebars: fsa k-force
Stem: fsa os 99

Saddle: selle italia slr
Tires: vittoria corsa
Bottlecage: elite carbon
Pedals: keo blade look



CORUM
SILVER REVO

Group: chorus meccanico
Wheels: fsa vision metron
Handlebars: fsa energy
Stem: fsa sl-k

Saddle: selle italia slr
Tires: vittoria corsa
Bottlecage: elite carbon
Pedals: keo max look

ELEGANZA
DI CLASSE

ÂGÉ
INOSSIDABILE



ÂGÉ
INOSSIDABILE

Group: chorus meccanico
Wheels: bora tubolare campy
Handlebars: fsa energy
Stem: fsa sl-k

Saddle: selle italia slr
Tires: vittoria corsa tubolare
Bottlecage: elite carbon
Pedals: keo max look

OLTRE
LA MODA

NUOVO CLASSICO



NUOVO CLASSICO

ROSSO CROMO

Group: chorus meccanico
Wheels: ruote shamal ultra
Handlebars: vero compact fsa
Stem: fsa sl-k

Saddle: selle italia slr
Tires: vittoria rubino pro
Bottlecage: elite carbon
Pedals: keo max look



NUOVO CLASSICO

AZZURRO CROMO

Group: chorus meccanico
Wheels: shamal ultra
Handlebars: fsa energy
Stem: fsa sl-k

Saddle: selle italia slr
Tires: rubino vittoria
Bottlecage: elite carbon race
Pedals: keo max look



TEMPERAMENTO
D'ALTRI TEMPI



NEO PRIMATO



NEO PRIMATO

BIANCO

Group: centaur 11v campy meccanico
Wheels: khamsin campy
Handlebars: fsa vero compact
Stem: fsa os 168

Saddle: selle italia x3
Tires: vittoria zaffiro
Bottlecage: elite custom race
Pedals: keo classic look

NEO PRIMATO



NEO PRIMATO

GREY

Group: potenza meccanico 11v
Wheels: zonda campy
Handlebars: fsa vero compact
Stem: fsa os 168

Saddle: selle italia slr in manganese
Tires: vittoria rubino pro
Bottlecage: elite custom race
Pedals: keo classic look



NEO PRIMATO

RED

Group: chorus 11v meccanico
Wheels: shamal ultra campy
Handlebars: fsa energy
Stem: fsa sl-k

Saddle: selle italia x3
Tires: vittoria corsa
Bottlecage: elite custom race
Pedals: keo max look



La leggerezza dell'intuizione.

Leggero e fondato, come le buone idee che restano: vi presentiamo l'alluminio.

Intuitively light.

Light with a strong foundation, just like good ideas that last: we present you with Aluminium.

Ci piace scherzare, dicendo che ogni giorno ci vestiamo un po' da esploratori. Osserviamo come i nostri ciclisti pedalano, ascoltiamo quello che ci raccontano da anni e poi, ecco, ci viene un'idea. L'ispirazione viene dal cuore, l'intuizione dall'attenzione continua alla ricerca. Ed è proprio da questo connubio che nel 1997 il nostro reparto di ricerca e sviluppo decide di iniziare a plasmare l'alluminio. C'era bisogno di leggerezza, e l'aria era l'elemento che ci ha ispirato. La storia che vi raccontiamo è questa: sul lungomare di Laigueglia, Ugo De Rosa è lì e osserva i turisti americani che pedalano con nuove biciclette alla moda, dai tubi imponenti.

L'intuizione è immediata: è necessario attualizzare la tendenza interpretando la cultura italiana votata alla prestazione e così nasce il telaio in alluminio che dona allo scheletro della bicicletta leggerezza e comfort. E siccome non ci accontentiamo mai, oggi quell'intuizione si rinnova: avete visto la Kermesse?

#creatività #velocità #estetica

We like to joke, saying that every day we dress up a bit like explorers. Let's observe how our cyclists ride, let's listen to what they tell us over the years and then, an idea presents itself! Inspiration comes from the heart, intuition from consistent research and attention to innovation. This was the wellspring that, in 1997, caused our R&D department to begin working with and shaping aluminum. There was a need for lightness, light as air was the phrase that inspired us; let us explain. On the seafront of Laigueglia, Ugo De Rosa is observing the American tourists who ride with new fashionable bicycles, made with imposing tubing. Intuition kicks in immediately, and we begin to actualize a future trend by infusing it with performance-based Italian cycling culture, giving rise to the birth of the aluminum frame, providing the skeleton of the bicycle a lightness and comfort not seen before. Because we are always driven by a dedication to continuous and never ending improvement, that intuition is renewed: have you seen the Kermesse?

#creativity #speed #aesthetic





“È prima di tutto bella. Che soddisfazione! Certo, è importante: la bicicletta me la guardo ogni sera e me la godo anche da solo, quando nel mio garage passo le sere a sistemarla, a montare nuovi accessori. Guai a chi entra. Beh, a parte le novità che De Rosa ci regala: quelle le aspetto volentieri! Visto la nuova Kermesse? » **Manuel**

“Mia moglie mi dice che sono spericolato, ed ha un po' di ragione. Ma amo la velocità e la leggerezza, che ci posso fare? La rassicuro grazie a voi, perché una bici De Rosa sa cos'è la stabilità, oltre a conoscere il brivido del vento. » **Giovanni**



*“It is above all beautiful; what satisfaction! Of course, it's important: I look at my bike every night and enjoy it alone when, in my garage, I spend the evenings cleaning it, tinkering with it and mounting new accessories. Woe to those who enter! Well, apart from anything new from De Rosa gives us: those are happy to wait for and hear! Seen the new Kermesse? » **Manuel***

*“My wife tells me I'm reckless and she is not entirely wrong, but I love speed and lightness so what can I do? I reassure her thanks to you, because a De Rosa bike understands stability as well as it understands the rush of the wind! » **Giovanni***

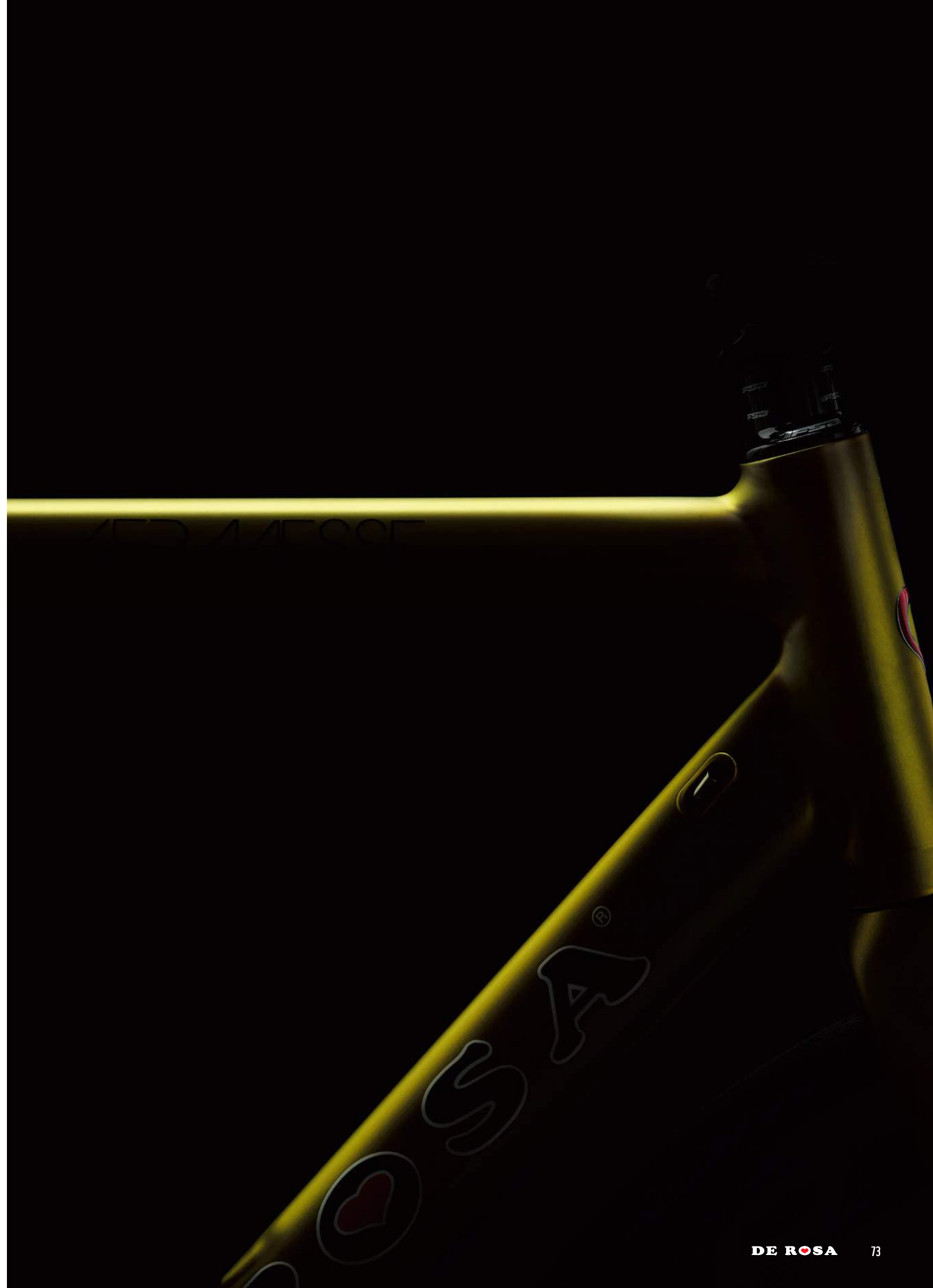

L'ALLUMINO
CHE SI RINNOVA



KERMESSE



KERMESSE

ORO

Group: chorus meccanico disk
Wheels: ruote bora one
Handlebars: fsa energy
Stem: fsa sl-k

Saddle: selle italia slr in manganese
Tires: vittoria corsa
Bottlecage: elite custom race
Pedals: keo max look

LA SFIDA
DELL'ALLUMINIO

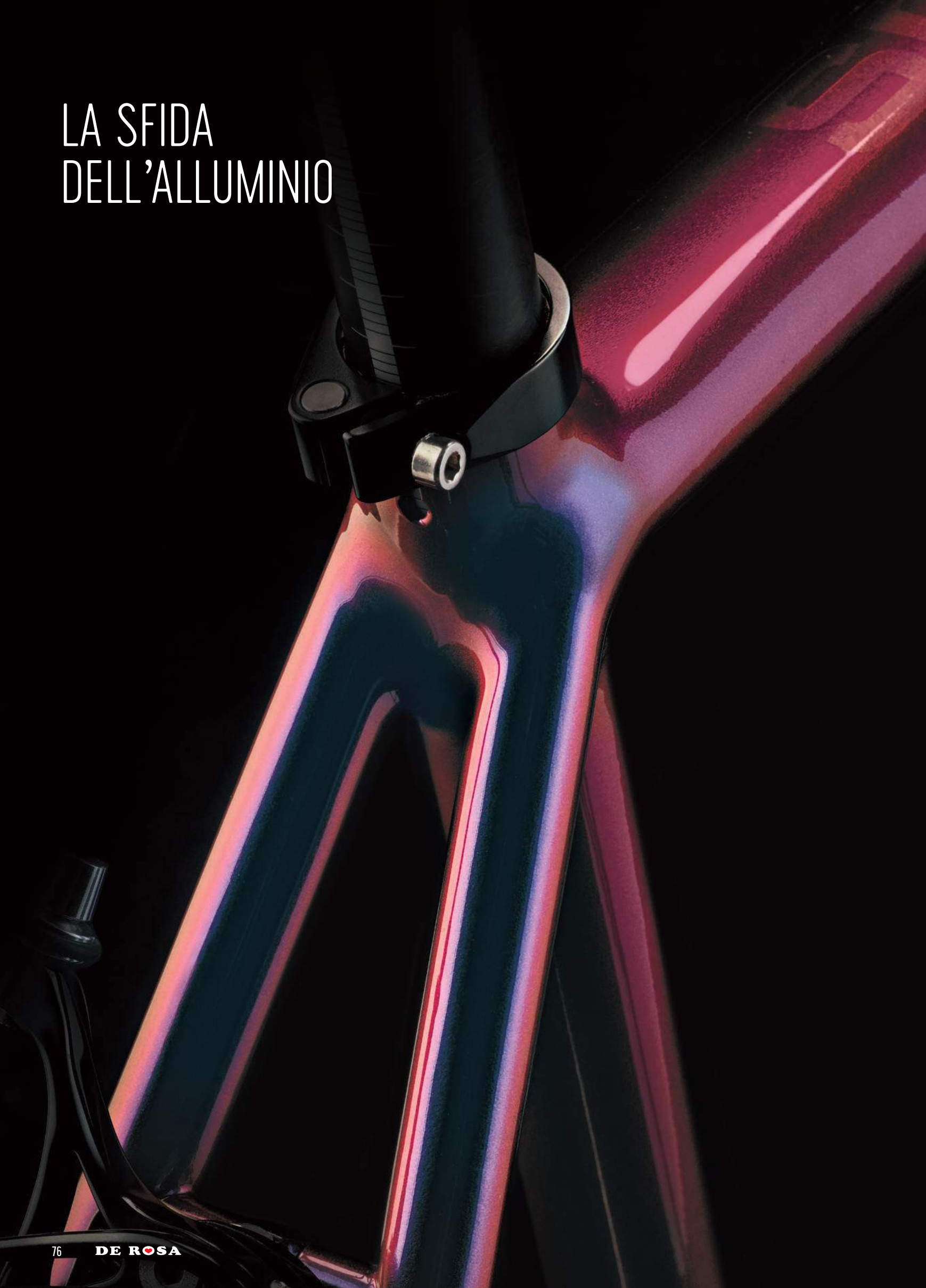

SCANDIUM



SCANDIUM

REFLEX

Group: chorus meccanico
Wheels: fsa vision metron
Handlebars: fsa k-force
Stem: fsa os 99

Saddle: selle italia slr
Tires: vittoria corsa
Bottlecage: elite carbon
Pedals: keo max look

IL FUTURO
PER VINCERE

TT-03



TT-03

Group: super record eps 11v con guarnitura bora
Wheels: bora campy
Handlebars: vision trimax carbon
Stem: attacco con telaio

Saddle: selle italia slr
Tires: vittoria corsa
Pedals: keo blade look

ANIMA URBANA E
ANIMA SPORTIVA

METAMORPHOSIS



METAMORPHOSIS

GREY

Group: alpine 8v disco
Handlebars: fsa energy

Stem: fsa sl-k
Saddle: selle italia slr



METAMORPHOSIS

CROMATA

Group: alpine 8v disco



TRA POLVERE
E GLORIA

OLTRE LA STRADA



BIGGER

VERDE

Group: xtr shimano disc 11 v meccanico
Wheels: ursus gomme barzo
Handlebars: fsa k-force
Stem: fsa k-force

Saddle: x-lr selle italia
Tires: vittoria zaffiro
Bottlecage: elite custom race
Pedals: shimano spd



BIG

AZZURRO

Group: deore xt meccanico
Wheels: vittoria reaxcion
Handlebars: fsa sl-k
Stem: fsa sl-k

Saddle: selle italia slr in manganese
Tires: vittoria corsa
Bottlecage: elite custom race
Pedals: shimano spd



SFIDA

SABBIA

Group: sram force one disk
Wheels: vision trimax30
Handlebars: fsa sl-k
Stem: fsa sl-k

Saddle: selle italia slr in manganese
Tires: vittoria cross
Bottlecage: elite custom race
Pedals: shimano spd



OSA

AZZURRO

Group: ultegra r8070 d2
Wheels: r6 fulcrum
Handlebars: fsa energy
Stem: fsa sl-k

Saddle: selle italia slr in manganese
Tires: vittoria rubino pro
Bottlecage: elite custom race
Pedals: keo max look

FARE SU MISURA



Black label è quel ponte presente che unisce la tradizione e il futuro

Black Label is the bridge that combines a solid tradition with the developments of the future

Gli occhi sono lo specchio dell'anima e per noi, in De Rosa, la bicicletta è la storia di chi la utilizza. È come fosse un racconto o, per dirla con reminiscenze scolastiche, è come fosse un tema dal titolo: "Descrivi te stesso".

Il pensiero che mi ritrovo a fare spesso, nonostante i tanti anni nel settore, è che la bici è l'unico mezzo che pesa meno di chi ne usufruisce. Non è una affermazione piena di fascino? Non ti lascia per un momento quel senso di piacevole smarrimento che si prova solo di fronte a un panorama dall'orizzonte infinito? A me personalmente fa questo effetto e da questa sensazione nasce il rapporto intimo e confidenziale tra l'uomo e il mezzo. Deve per forza crearsi un'alchimia e una intesa che sfiorano la perfezione. Su questo breve percorso di parole, anni fa è nato Black Label, il progetto che allora festeggiava i nostri primi 60 anni e che garantisce a ogni individuo la bicicletta fatta su misura.

The eyes are the mirror of the soul and for us at De Rosa the bicycle is a reflection of the rider. It's like a story or to say it in a way that brings us back to our school years when the teacher asked us to write a story the theme of which was "Describe yourself."

The thought I revert to quite often, even after being in the cycling industry for so many years, is that the bike is the only mode of transportation that weighs significantly less than those who enjoy it. Isn't this charming as well as ironic? Does it not leave you with the same sense of infinity and at the same loss that you experience in the face of an infinite horizon? Personally, I feel this effect, and from this feeling comes the intimate and almost secret relationship between man and machine. This is a necessary alchemy and an understanding that presupposes perfection. It was this feeling and very concise description in words which gave rise to our Black Label program, the project that celebrates our first 60 years and which guarantees each individual participant a custom made bicycle.



A chiunque desideri una De Rosa taylor made, Black Label offre un processo creativo personalizzato, la scelta del materiale e dei singoli dettagli. Noi ci mettiamo tutto il resto: studio, analisi, qualità, artigianalità, cura, esperienza, eccellenza. Ci dedichiamo: e qui sta la differenza. Ogni nostro artigiano impiega il proprio tempo a confezionare il prodotto destinato ad essere unico.

Black Label è quel ponte presente che unisce la tradizione e il futuro e sul quale stiamo investendo energia e impegno per proporre elementi esclusivi sui quali sia impressa la personalità di chi pedala, sia nel design, dunque nella forma e nell'estetica, sia nella tecnologia. È quello sforzo che ci fa uscire dalla pigrizia del pensiero che bloccherebbe qualsiasi crescita e che ci proietta oltre, verso terreni sconfinati perché soddisfare le tue esigenze significa anche evolvere come azienda e imparare a mettere in gioco sempre la nostra creatività. Tutto siglato dal "saper fare" italiano, da quella bellezza profonda e onnicomprensiva che il mondo chiama e riconosce come Made in Italy.

E per tornare all'inizio di questo mio pensiero, far nascere una bicicletta e far nascere la tua bicicletta ha una anima diversa.

A custom made De Rosa under the Black Label program offers a completely creative process with choices of material and individually specified details which require study, analysis, quality, craftsmanship, care, experience, and a commitment to excellence. We devote and invest ourselves in the project and here is the difference: each of our craftsman take the time to add their personal touches so that each finished product is completely unique.

Black Label is a program in which we are investing energy and commitment to propose exclusive elements in order for the unique personality of the cyclist is impressed, both in design - therefore in form and in aesthetics - and technology. It forces us to look beyond what is available now, into the endless land of the future so that we may meet your needs and exceed your expectation. Everything stems from our being Italian and knowing how to create the profound and all-encompassing beauty the world describes as "made in Italy".

To go back to the beginning and my original thought, to initiate the birth and then nurture the growth of a bicycle that has its own unique soul.





I nostri team

Our teams

Tre squadre, tre mondi, tre anime che pedalano De Rosa e che sosteniamo con passione. La spagnola Caja Rural, la Israel Cycling Academy e la Nippo Vini Fantini sono tre forze del racing che hanno l'anima di Cusano Milanino, perché esprimono la forza della tradizione e il coraggio di innovare. Ciascuna con il suo carattere: il multiculturalismo delle nazioni del team israeliano, la tradizione forte del ciclismo della Spagna e la squadra che in Italia è cresciuta con noi, mettendo insieme cultura italiana e giapponese. Lingue diverse, paesi diversi, progetti diversi che salgono sulla sella con lo stesso obiettivo, accomunati dallo stesso sforzo. Siamo con loro.



Three teams each with their own unique soul whose homes are in three different areas of the world ride DeRosa, supported by our passion for the bike and those that ride them. Although the homes of these teams are spread throughout the world, with home bases in Spain (Caja Rural), Israel (Israel Cycling Academy) and Italy (Nippo Vini Fantini), these three racing forces are infused with the soul of Cusano Milanino because just like DeRosa they embody both the strength of tradition and the courage to innovate while each maintains its own unique character: the multiculturalism of the Israeli team, the strong tradition of cycling in Spain and the team that began and has grown with us in Italy that has brought together Italian and Japanese culture. Different languages, different countries, different projects whose team members mount their bikes with the same objective, united by the same goal. We are with them through each stroke of the pedal.



PROTOS

specifiche tecniche | technical specifications

ACF cm	BR cm	C cm	D°	E cm	F cm	G cm	REACH	STACK
45	50.7	40.5	75°	27	10.3	57.8	37.1	49.6
47	52	40.5	74°50'	27	11.6	58.3	37.6	51
49	53.3	40.6	73°90'	27	12.7	58.4	38	52.3
51	54.6	40.6	73°50'	27	13.8	58.7	38.5	53.8
53	55.5	40.7	73°30'	27	14.9	58.8	38.9	55
55	56.5	40.7	73°	27	16	59.3	39.3	56.1
57	57.8	40.8	72°70'	27	17.6	60.2	39.8	57.7
58.5	59.2	40.8	72°50'	27	19.5	61.4	40.4	59.5

Frame	Fork	Headset Size	BB Size	Seatpost
920gr	370gr	1 1/8 + 1 1/4	ITALIAN	DEDICATED

colori | colors

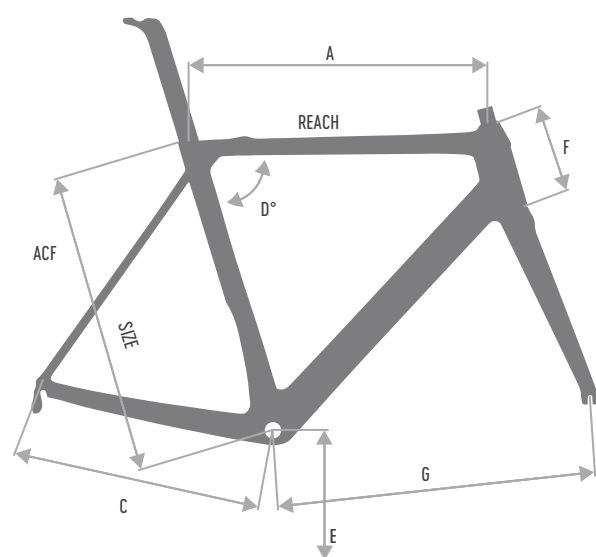

KING

specifiche tecniche | technical specifications

ACF cm	BR cm	C cm	D°	E cm	F cm	G cm	REACH	STACK
41.7	50.5	40.2	75°30'	26.8	11	58	37.2	50.1
45	50.7	40.2	75°	26.8	11	57.3	37	50.4
47	51.9	40.2	75°	26.8	11.7	57.6	38	51.5
49	53.4	40.4	74°40'	26.8	12.6	57.9	38.7	52.6
51	54.5	40.5	73°90'	26.5	13.4	58.3	39	53.5
53	55.5	40.7	73°50'	26.5	14.4	58.6	39.3	54.5
55	56.5	40.9	73°	26.5	15.6	59.1	39.5	55.7
57	57.5	41	72°60'	26.5	17	59.7	39.7	57
59	58.9	41	72°60'	26.5	19	60.9	40.5	59

Frame	Fork	Headset Size	BB Size	Seatpost
950gr	370gr	1 1/8 + 1 1/4	86.5x46	DEDICATED (31.6)

colori | colors



le TUE geometrie | YOURS geometries

ACF cm	BR cm	C cm	D°	E cm	F cm	G cm	REACH	STACK
-	-	-	-	-	-	-	-	-

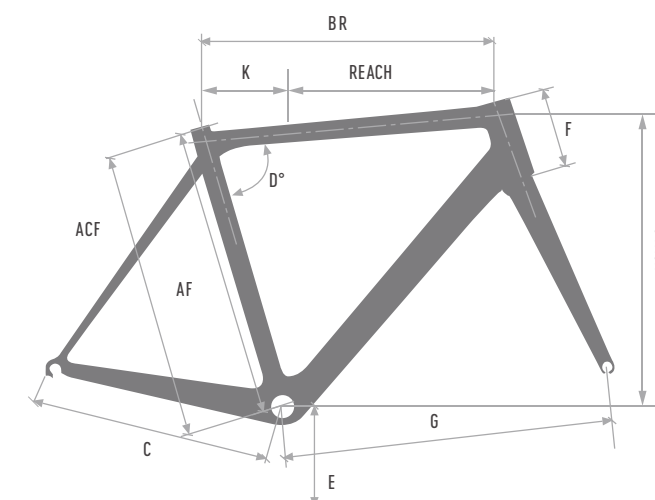

SK PININFARINA

specifiche tecniche | technical specifications

SIZE	A mm	B mm	C°	D°	G mm	F mm	REACH	STACK
460	503	82	74°60'	70°70'	569	396	369	478
480	516	100	74°30'	70°90'	579	396	374	496
500	528	118	74°	71°20'	587	398	379	514
520	541	136	73°70'	71°40'	596	398	384	532
540	553	148	73°40'	72°70'	588	400	389	550
560	567	166	73°10'	72°90'	596	400	394	568
580	580	184	72°80'	73°20'	604	402	399	586
600	594	202	72°50'	73°40'	612	402	404	604

Frame	Fork	Headset Size	BB Size	Seatpost
990gr	370gr	1 1/8 + 1 1/4	86.5x46	DEDICATED

colori | colors

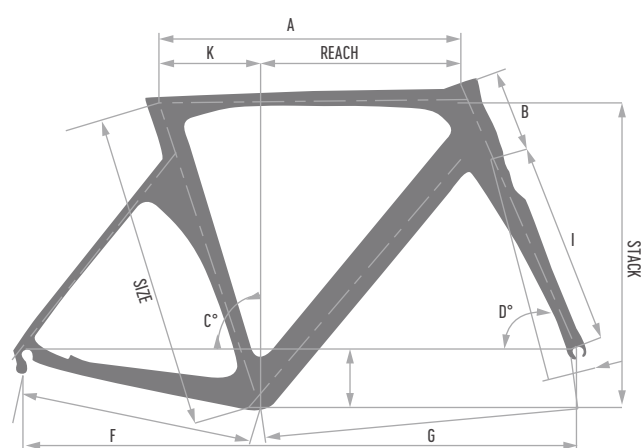

IDOL

specifiche tecniche | technical specifications

SIZE	A cm	B cm	C°	D°	G cm	F cm	REACH	STACK
47	51.7	11.1	74°20'	71°	578	40.6	37	50.7
49.5	52.9	11.8	73°90'	72°	580	40.8	37.8	51.7
52	54.3	13.5	73°60'	72°60'	580	40.8	38.4	53.7
54.5	56	15.4	73°	73°	588	41	39	55.7
57	57.2	17.5	73°	73°10'	599	41	39.6	57.7
59.5	58.8	19.5	72°70'	73°30'	609	41.2	40.2	59.7

Frame	Fork	Headset Size	BB Size	Seatpost
1250gr	370gr	1 1/8 + 1 1/4	86.5x46	31.6

colori | colors

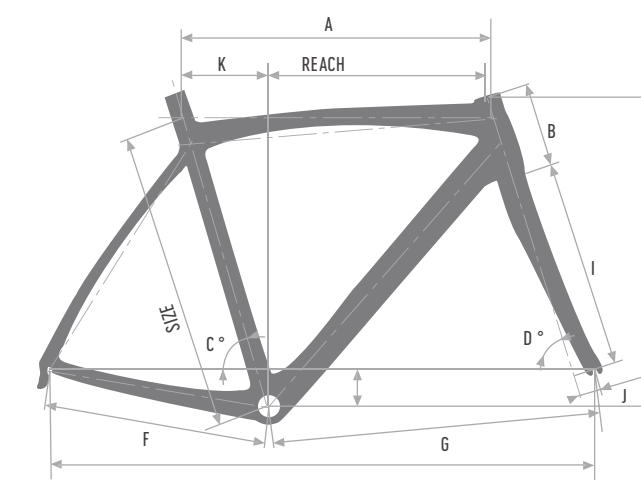

NICK

specifiche tecniche | technical specifications

SIZE	A mm	B mm	D mm	E°	F°	G mm	H mm
462	412	462	102	74°50	72°	71	406
480	430	480	125	74°10	72°20	71	406
498	448	498	145	73°70	72°40	69	406
522	467	522	165	73°30	72°60	69	406
545	485	545	182	72°90	73°30	69	406

Frame	Fork	Headset Size	BB Size	Seatpost
1000gr	370gr	1 1/8 + 1 1/2	86.5x46	31.6

colori | colors

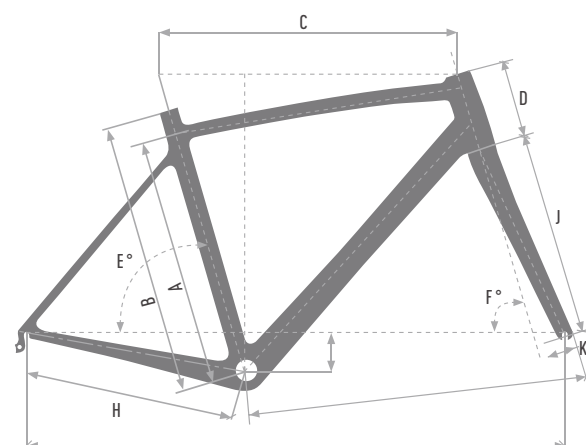

SOLO

specifiche tecniche | technical specifications

ACCS cm	ACCR cm	BR cm	C cm	D°	F cm	G cm
44	48	51	39.8	76°	10.4	58
45	49	52	40.10	75° 25	11.1	58
45	50	52.5	40.10	75°15	12.2	58.1
46	51	53	40.20	75°	13.0	58.1
47	52	53.5	40.40	74°30	13.7	58.2
48	53	54	40.45	74°15	14.6	58.3
49	54	54.5	40.55	74°	15.4	58.4
50	55	55	40.65	73°45	16.5	58.6
51	56	56	40.85	73°10	17.3	59
52	57	56.5	40.90	73°	18.1	59.2
53	58	57.5	40.90	73°	19.2	60.2
54	59	58	41.00	72°45	20.2	60.4
55	60	58.5	41.10	72°30	21.2	60.6

Frame	Fork	Headset Size	BB Size	Seatpost
1400gr	370gr	1 1/8 + 1 1/8	ITALIAN	31.6

colori | colors



le TUE geometrie | YOURS geometries

ACCS cm	ACCR cm	BR cm	C cm	D°	F cm	G cm
-	-	-	-	-	-	-

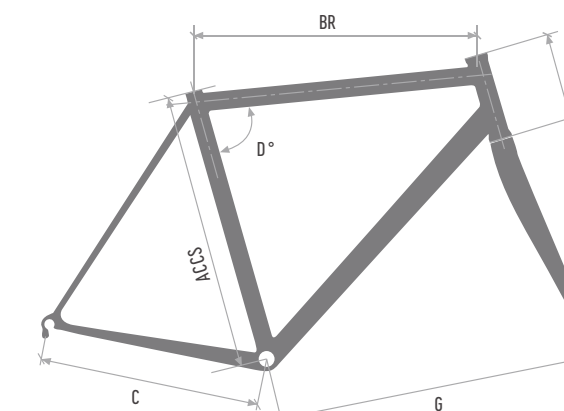

ANIMA

specifiche tecniche | technical specifications

SLOPE	ACCS	BR cm	C cm	D°	F cm	G cm
44	51	39,80	76°	10,4	58	
45	52	40,10	75°30	11,1	58	
46	53	40,20	75°	12,2	58,1	
48	54	40,45	74°15	13,7	58,3	
49	54,5	40,55	74°	14,6	58,4	
50	55	40,65	73°30	15,4	58,6	
51	56	40,85	73°	16,5	59	
52	56,5	40,90	73°	17,3	59,20	
53	57,5	40,90	73°	18,1	60,2	
55	58,5	41,10	72°30	20,2	60,60	

colori | colors



le TUE geometrie | YOURS geometries

ACCR cm	BR cm	C cm	D°	E cm	F cm	G cm
-	-	-	-	-	-	-

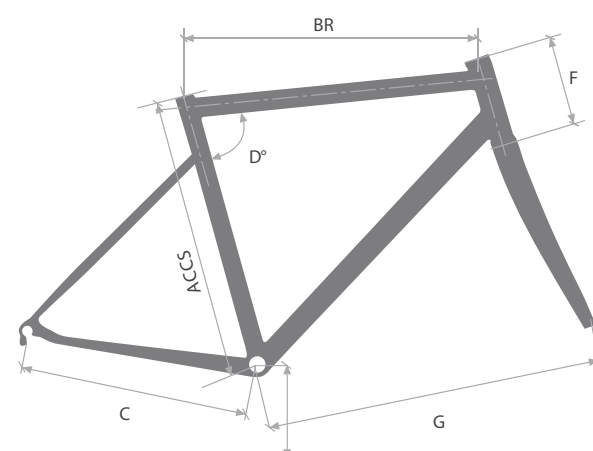

TREDUECINQUE

specifiche tecniche | technical specifications

ACCS cm	ACCR cm	BR cm	C cm	D°	F cm	G cm
44	48	51	39.8	76°	10.4	58
45	49	52	40.10	75° 25	11.1	58
45	50	52.5	40.10	75°15	12.2	58.1
46	51	53	40.20	75°	13.0	58.1
47	52	53.5	40.40	74°30	13.7	58.2
48	53	54	40.45	74°15	14.6	58.3
49	54	54.5	40.55	74°	15.4	58.4
50	55	55	40.65	73°45	16.5	58.6
51	56	56	40.85	73°10	17.3	59
52	57	56.5	40.90	73°	18.1	59.2
53	58	57.5	40.90	73°	19.2	60.2
54	59	58	41.00	72°45	20.2	60.4
55	60	58.5	41.10	72°30	21.2	60.6

Frame	Fork	Headset Size	BB Size	Seatpost
1400gr	370gr	1 1/8 + 1 1/8	ITALIAN	31.6

colori | colors



le TUE geometrie | YOURS geometries

ACCS cm	ACCR cm	BR cm	C cm	D°	F cm	G cm
-	-	-	-	-	-	-

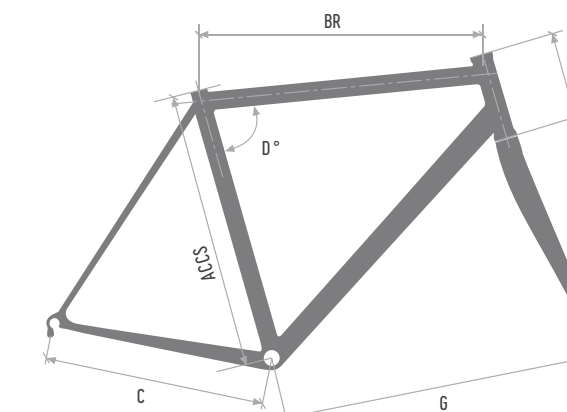

CORUM

specifiche tecniche | technical specifications

SLOPE	ACCS	ACCR cm	BR cm	C cm	D°	F cm	G cm
44	48	52	39,95	75°30	10,2	58	
45	49	52,2	39,95	75°30	10,9	58	
45	50	52,5	40,00	75°15	12	58	
46	51	53	40,05	75°	12,8	58,12	
47	52	53,5	43,30	74°30	13,5	58,15	
48	53	54	40,45	74°15	14,4	58,23	
49	54	54,5	40,55	74°	15,2	58,36	
50	55	55	40,60	73°45	16,3	58,60	
51	56	56	40,80	73°10	17,1	58,96	
52	57	56,5	40,85	73°	17,9	59,20	
53	58	57,5	40,85	73°	19	60,20	
54	59	58	40,95	72°45	20	60,42	
55	60	58,5	41,05	72°30	21	60,65	
56	61	59	41,05	72°30	21,8	61,14	
57	62	59,5	41,20	72°15	22,7	61,32	

Frame	Fork	Headset Size	BB Size	Seatpost
1.700gr	350gr	1 1/8 + 1 1/8	ITALIAN	29.4

colori | colors



le TUE geometrie | YOURS geometries

SLOPE	ACCS	ACCR cm	BR cm	C cm	D°	F cm	G cm
-	-	-	-	-	-	-	-

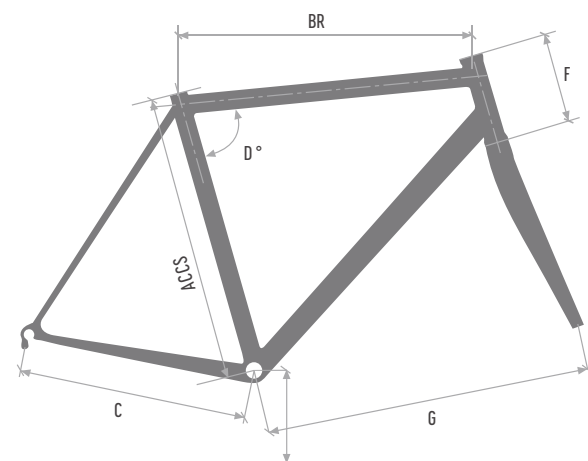

NUOVO CLASSICO

specifiche tecniche | technical specifications

ACCR cm	BR cm	C cm	D°	E cm	F cm	G cm
48	52	40	75°30	26.5	8.2	57.5
49	52	40	75°30	26.5	9.2	57.5
50	52.5	40	75°15	26.5	10.2	58
51	53	40	75°	26.5	10.9	58
52	53.5	40.3	74°30	26.5	11.9	58
53	54	40.5	74°15	26.5	12.6	58.2
54	54.5	40.7	74°	26.5	13.6	58.4
55	55	40.7	73°50	26.5	14.4	58.6
56	56	40.8	73°10	26.5	15.3	59
57	56.5	40.8	73°	26.5	16.3	59.4
58	57.5	40.8	73°	26.5	17.2	59.7
59	58	40.9	72°50	26.5	18.2	60
60	58.5	41	72°45	26.5	19.2	60.3
61	59	41.2	72°30	26.5	20.2	60.8

Frame	Fork	Headset Size	BB Size	Seatpost
1700gr	600	1 THREADED	ITALIAN	27.2

colori | colors



le TUE geometrie | YOURS geometries

ACCR cm	BR cm	C cm	D°	E cm	F cm	G cm
-	-	-	-	-	-	-

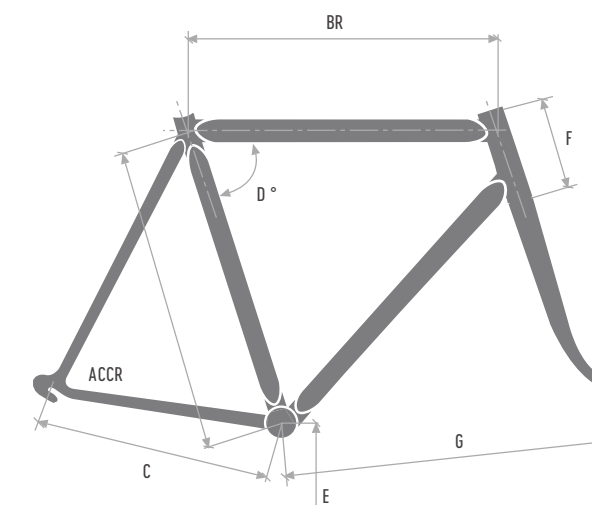

ÂGÉ

specifiche tecniche | technical specifications

ACCR cm	BR cm	C cm	D°	E cm	F cm	G cm
48	52	40	75°30	26.7	8.4	57.5
49	52	40	75°30	26.7	9.2	57.5
50	52.5	40	75°15	26.7	10.2	57.8
51	53	40	75°	26.7	10.9	58
52	53.5	40.2	74°15	26.6	11.9	58
53	54.5	40.5	74°15	26.6	12.6	58.2
54	55	40.7	74°	26.6	13.6	58.4
55	55.5	40.7	73°45	26.6	14.4	58.6
56	56.5	40.8	73°30	26.6	15.3	58.8
57	57	40.8	73°15	26.6	16.3	59.2
58	57.5	40.8	73°	26.6	17.2	59.6
59	58	40.9	73°	26.6	18.2	59.8
60	58.5	41	72°45	26.6	19.2	60.3
61	59	41.1	72°30	26.6	20.2	60.8

Frame	Fork	Headset Size	Bd Size	Seatpost
1850gr	660gr	1" THREADED 11/8 + 11/2	ITALIAN	27.2

colori | colors



le TUE geometrie | YOURS geometries

ACCR cm	BR cm	C cm	D°	E cm	F cm	G cm
-	-	-	-	-	-	-

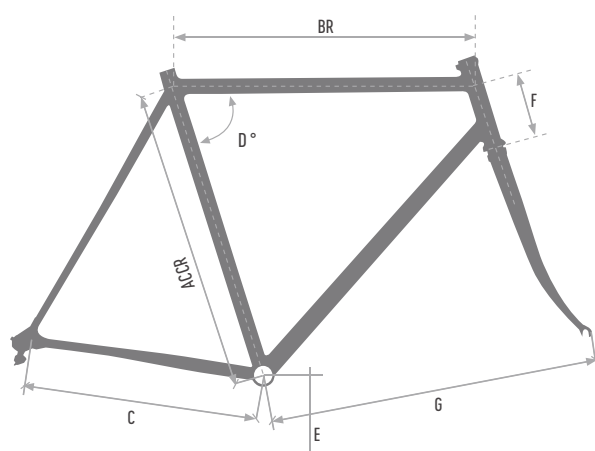

NEO PRIMATO

specifiche tecniche | technical specifications

ACCR cm	BR cm	C cm	D°	E cm	F cm	G cm
48	52	40	75°30	26.5	8.2	57.5
49	52	40	75°30	26.5	9.2	57.5
50	52.5	40	75°15	26.5	10.2	58
51	53	40	75°	26.5	10.9	58
52	53.5	40.3	74°30	26.5	11.9	58
53	54	40.5	74°15	26.5	12.6	58.2
54	54.5	40.7	74°	26.5	13.6	58.4
55	55	40.7	73°50	26.5	14.4	58.6
56	56	40.8	73°10	26.5	15.3	59
57	56.5	40.8	73°	26.5	16.3	59.4
58	57.5	40.8	73°	26.5	17.2	59.7
59	58	40.9	72°50	26.5	18.2	60
60	58.5	41	72°45	26.5	19.2	60.3
61	59	41.2	72°30	26.5	20.2	60.8

Frame	Fork	Headset Size	BB Size	Seatpost
1700gr	600gr (forca in acciaio) 400gr (forca in carbonio)	1 THREADED 1 FLAT (carbonio)	ITALIAN	27.2

colori | colors



le TUE geometrie | YOURS geometries

ACCR cm	BR cm	C cm	D°	E cm	F cm	G cm
-	-	-	-	-	-	-

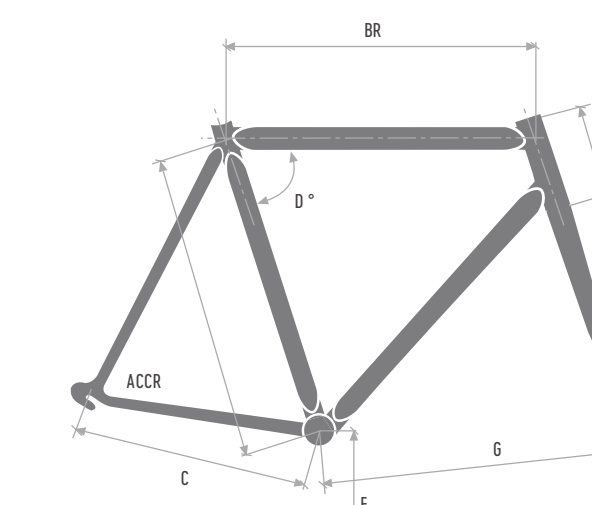

KERMESSE

specifiche tecniche | technical specifications

ACF cm	BR cm	C cm	D°	F cm	G cm
49	51,5	41	75°	12,8	57,5
52	54,5	41,5	74°	13,7	58,3
56	56,5	42,00	73°	16,5	59
58	58	42	73°	18,4	59,8

colori | colors



le TUE geometrie | YOURS geometries

ACF cm	BR cm	C cm	D°	E cm	F cm	G cm
-	-	-	-	-	-	-

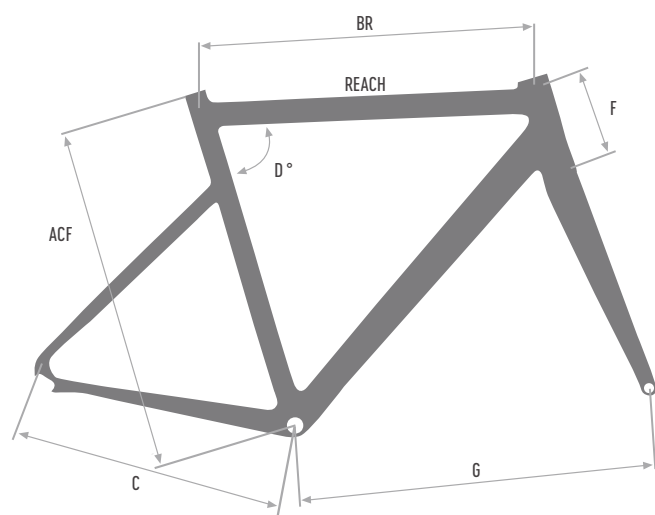

TT-03

specifiche tecniche | technical specifications

SIZE	A mm	B mm	Q1°	Q3°	I mm	H mm	REACH	STACK
534	534	410	70°50'	75°	75	65	351	469
546	546	436	71°	75°	85	70	363	480
559	559	445	71°50'	75°	93.7	70	375	490
575	575	456	72°	75°	102.4	70	390	500

Frame	Fork	Headset Size	BB Size	Seatpost
1.200gr	500gr	1 1/8 + 1 1/4	86.5x46	DEDICATED

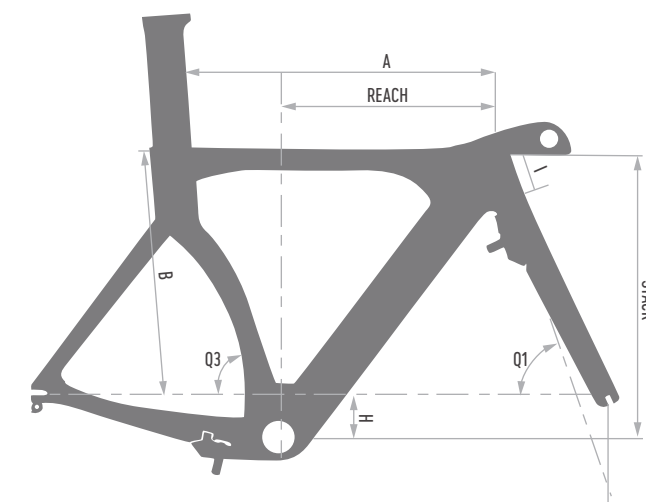

SCANDIUM

specifiche tecniche | technical specifications

ACF cm	BR cm	C cm	D°	E cm	F cm	G cm
45 sl	52	40.5	75°	26.8	12.8	57.5
46.5 sl	53.5	40.5	74°50'	26.8	13.2	57.7
48 sl	54.5	40.7	74°30'	26.8	13.7	58.1
49 sl	55.5	40.7	74°	26.8	14.5	58.6
52 sl	56.5	41	73°	26.8	16.5	59
54 sl	57.5	41	73°	26.8	18.4	59.5
58 reg	58.5	41.2	72°50'	26.8	18.4	60
60 reg	60	41.2	72°50'	26.8	20.5	61

Frame	Fork	Headset Size	Bd Size	Seatpost
1280gr	370gr	1 1/8 + 1 1/4	86.5x41	31.6

colori | colors



le TUE geometrie | YOURS geometries

ACF cm	BR cm	C cm	D°	E cm	F cm	G cm
-	-	-	-	-	-	-

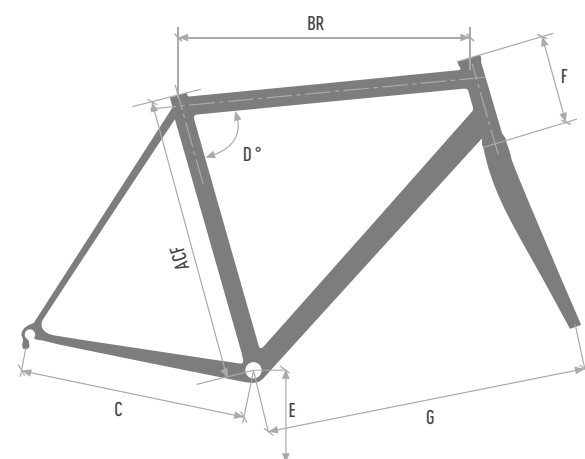

METAMORPHOSIS

specifiche tecniche | technical specifications

SIZE
S
M
L

colori | colors

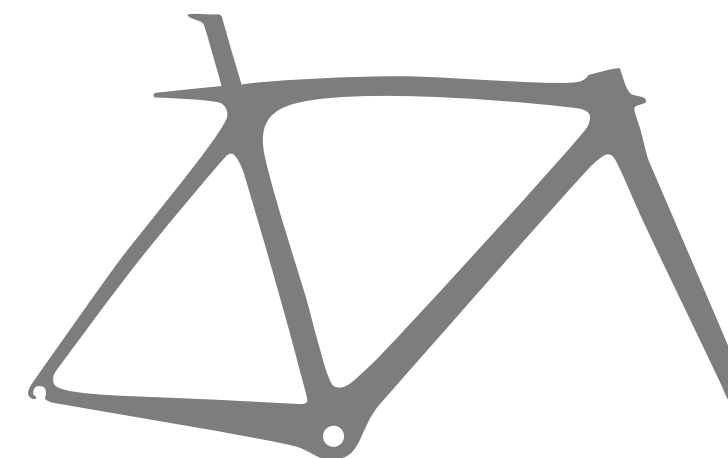

BIGGER

specifiche tecniche | technical specifications

SIZE	BR mm	ACF mm	C mm	D°	F mm
S	570	409	440	73°5	95
M	594	444	440	71°7	100
L	619	482	440	72°5	125
XL	638	633	440	72°5	145

disponibile sia con forcella rigida che ammortizzata
available with rigid or suspended fork

colori | colors

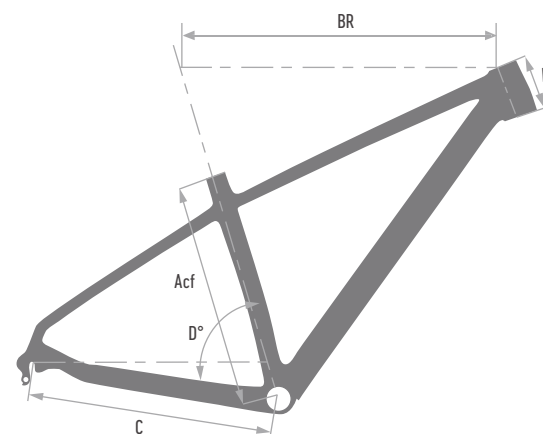

BIG

specifiche tecniche | technical specifications

SIZE	BR mm	ACF mm	C mm	D°	F mm
S/M	552	400	425	73°5	93
L/XL	583	445	425	73°5	105

disponibile sia con forcella rigida che ammortizzata
available with rigid or suspended fork

colori | colors

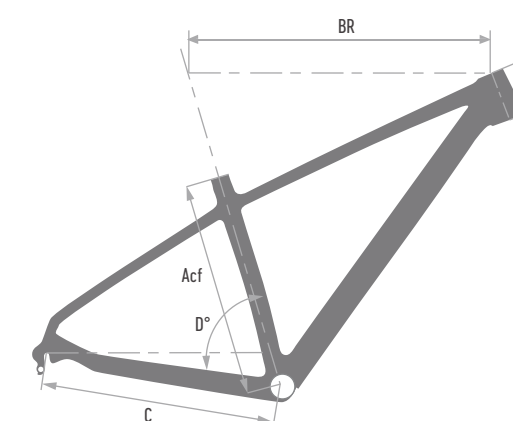

SFIDA

specifiche tecniche | technical specifications

SIZE	BR mm	ACF mm	C mm	D°	F mm
S	505	510	425	74°5	115
M	534	550	425	74°	145
L	556	590	425	74°	175

colori | colors

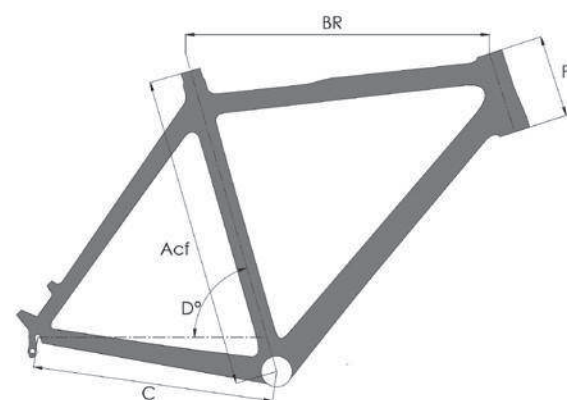

OSA

le TUE geometrie | YOURS geometries

SLOPE ACCS	ACCR cm	BR cm	C cm	D°	F cm	G cm
-	-	-	-	-	-	-

colori | colors

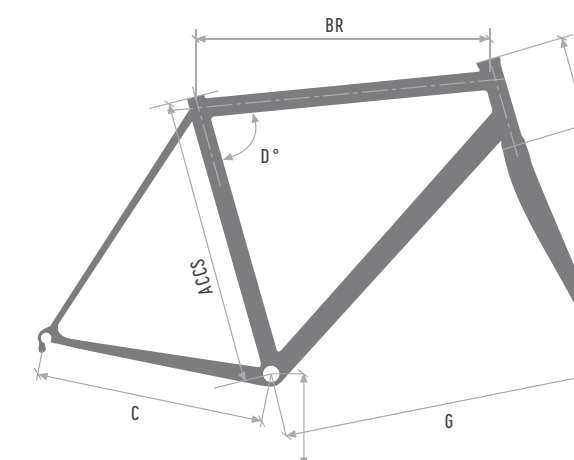

Agency: Prograf Find Solutions

Art Direction: Elisabetta Conter
Photography: Ginevra Frigo
Emiliano Sterza

Copywriter: Nico Cattapan
Sun-TIMES
MarroneCattelan

Print: Prograf Find Solutions
Supervision: Cristiano De Rosa



De Rosa Ugo & Figli Srl
Via Bellini, 24 - 20095 Cusano Milanino, Milano - Italy
T. +39 02 61 95 171 - F. +39 02 61 95 188

www.derosa.it